

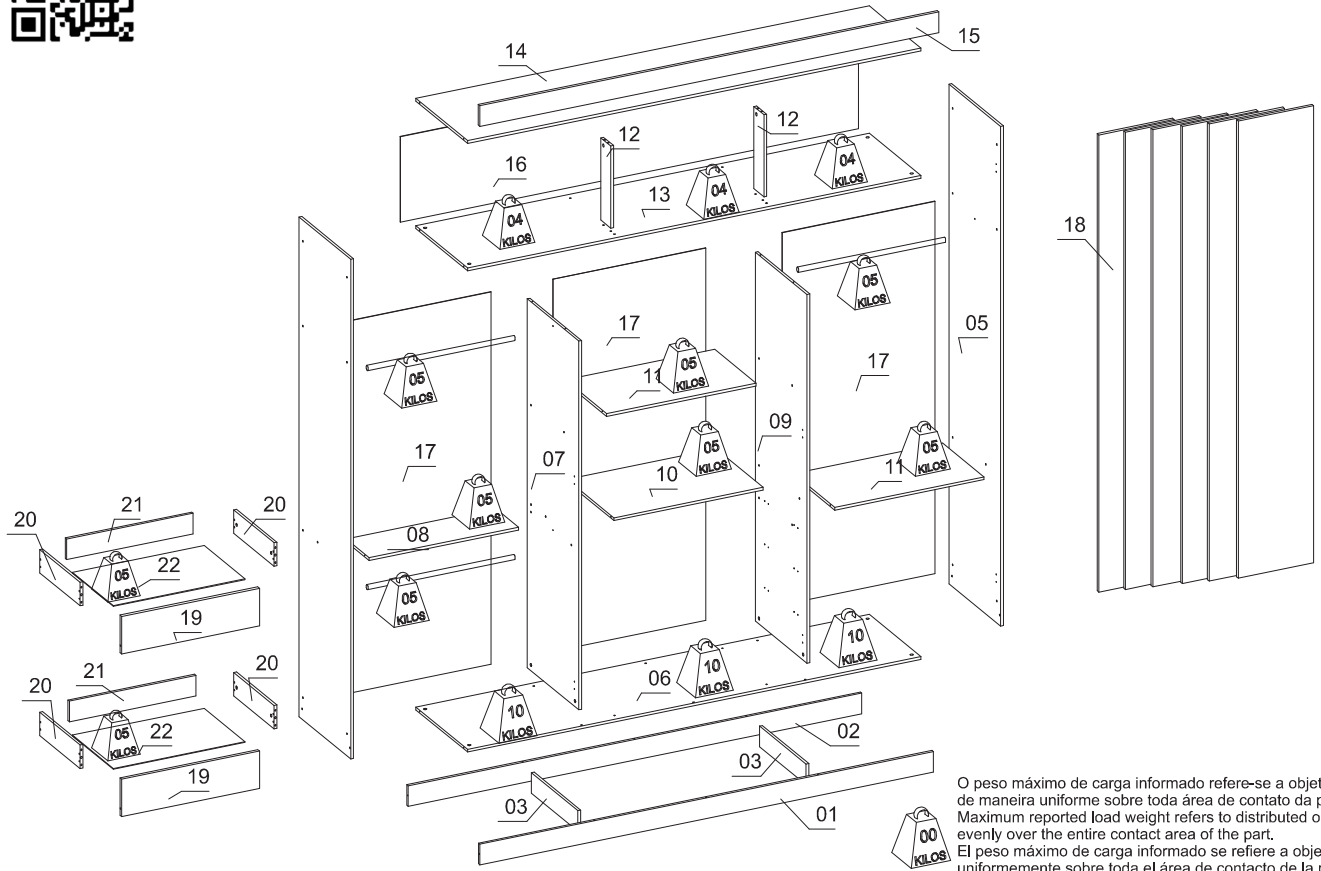

### 8605 - GR AMAROK 6 PORTAS



O peso máximo de carga informado refere-se a objetos distribuído de maneira uniforme sobre toda área de contato da peça.  
 Maximum reported load weight refers to distributed objects evenly over the entire contact area of the part.  
 El peso máximo de carga informado se refiere a objetos distribuidos uniformemente sobre toda el área de contacto de la pieza.



### LISTA DE PEÇAS / Pieces List / Lista de Piezas

SEQ.	REF.	DESCRIÇÃO	DESCRIPTION	DESCRIPCIÓN	MAT.PRIMA	COMP.	LARG.	ESP.	QTD.
01	316482	RODAPE FRONTAL	FRONT FOOTING	ZOCALO FRONTAL	MDP	1974	88	12	1
02	316483	RODAPE TRASEIRO	BACK FOOTING	ZOCALO TRASEIRO	MDP	1974	88	12	1
03	316484	TRAVA DO RODAPE	LOCKOUT	TRAVA RODAPE	MDP	404	88	12	2
04	316485	LATERAL ESQUERDA	LET SIDE	LATERAL IZQUIERDO	MDP	2130	450	12	1
05	316486	LATERAL DIREITA	RIGHT SIDE	LATERAL DERECHO	MDP	2130	450	12	1
06	316487	BASE	BASE	BASE	MDP	1974	450	12	1
07	316488	DIVISORIA ESQUERDA	LEFT DIVISION	DIVISORÍA IZQUIERDA	MDP	1572	450	12	1
08	316490	PRATELEIRA MENOR	SMALL SHELF	ESTANTE PEQUEÑO	MDP	650	200	12	1
09	316492	DIVISORIA DIREITA	RIGHT DIVISION	DIVISORÍA DERECHA	MDP	1572	450	12	1
10	316493	TAMPO DO GAVETEIRO	DRAWER TOP	CAJÓN SUPERIOR	MDP	650	410	12	1
11	316494	PRATELEIRA MAIOR	LARGEST SHELF	ESTANTE MÁS GRANDE	MDP	650	360	12	2
12	316495	BATENTE	STOP	BATERÍA	MDP	350	88	12	2
13	316496	BASE DO MALEIRO	MALEIRO BASE	BASE MALEIRO	MDP	1974	450	12	1
14	316497	CHAPEU	HAT	SOMBRERO	MDP	1974	450	12	1
15	316498	VISTA SUPERIOR	UPPER VIEW	VISTA SUPERIOR	MDP	1998	88	15	1
16	316499	FUNDO SUPERIOR	TOP BACKGROUND	FONDO SUPERIOR	HDF	1994	364	3	1
17	316500	FUNDO	BACKGROUND	FONDO	HDF	1587	665	3	3
18	316501	PORTA	Door	Puerta	MDP	1949	328	15	6
19	316502	FRENTE GAVETA	Drawer background	Frente del cajón	MDP	600	160	15	2
20	700471	LATERAL GAVETA	Side drawer	Lateral cajon	MDP	350	100	12	4
21	316504	CONTRA FUNDO	Against bottom	Contra la parte inferior	MDP	551	88	12	2
22	316505	FUNDO GAVETA	Drawer Background	Fondo de cajon	HDF	573	355	3	2

## INSTRUÇÃO MONTAGEM PRODUTO

Intructions to Assembly / Instrucciones de montaje



Separar as peças e acessórios de maneira organizada  
Separate parts and accessories in way organized  
Separar las piezas y accesorios de manera organizada



Forrar o chão com o papelão das embalagens.  
Cover the floor with the cardboard  
Cubra el suelo con la embalaje de cartón



É necessário 01 pessoa para montar o produto  
It is necessary one person to assembly  
Es necesario una persona para ensamblar

O produto deve ser a montado por um profissional qualificado  
The product must be assembly by a professional  
El producto debe ser ensamblado por un profesional calificado

Ferramentas necessárias  
(não fornecidas)  
Not include tools / No herramientas



## CUIDADO PARA CONSERVAÇÃO E LIMPEZA DO MÓVEL

Care to conservation and clean / Cuidados de limpieza

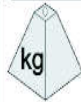

O peso máximo de carga informado refere-se a objetos distribuído de maneira uniforme sobre toda área de contato da peça  
Set maximum weight load refers to objects distributed uniformly over the entire contact area of the workpiece.  
Conjunto de carga máxima de peso se refiere a objetos distribuidos uniformemente sobre toda el área de contacto de la pieza de trabajo.



Não molhar o móvel e não expor em lugar úmido  
Do not wet the mobile and do not expose in a wet place  
No moje el producto y no exponer en un lugar húmedo



Não expor o móvel próximo de fontes de calor.  
Do not expose the mobile near heat sources  
no exponga cercano de fuentes de calor



Não usar produtos abrasivos.  
Do not use abrasive products.  
No utilice productos abrasivos.



Limpe com flanela limpa e seca.  
Clean with dry cloth  
Limpieza con un paño limpio y seco

## LISTA DE ACESSÓRIOS E FERRAGEM / ACCESSORIES AND HARDWARE / ACCESORIOS Y EQUIPOS



A - 700137-Parafuso 4,5x45 (48x)  
screw / tornillo



B- 700124-Parafuso 3,5x25 (20x)  
screw / tornillo



C- 700121-Parafuso 3,5x12 (30x)  
screw / tornillo



D- 700120-Parafuso 3,0x12 (12x)  
screw / tornillo



E- 700130-Parafuso 4,0x16 (16x)  
screw / tornillo



F- 700142-Parafuso 6,0x12 (8x)  
screw / tornillo



G- 700127-Parafuso 4,0x12 (72x)  
screw / tornillo



H- 700542-Cavilha 6x30 (10x)  
peg / cerrojo



I- 700538-Cantoneira (9x)  
corner / esquina



J- 700547-Junção (35x)  
junction / juncion



K- 700146-Parafuso minifix (10x)  
Minifix screw /  
Tornillo minifix



L- 700148-Tambor Minifix (10x)  
Minifix Drum /  
Tambor minifix



M- 700157-Prego (138x)  
nail / clavo



N- 700395-Dobradiça (18x)  
700390-Calço (18x)  
hinge / bisagra



O- 700165-Puxador 250 mm (6x)  
Handle / Manija



P - 700464-Pés de ropeiro (8x)  
wardrobe feet / pies guardarropa



Q - 700111- Corrediça (02x)  
runners / corredera



R-700438-Suporte cabide (6X)  
hook support / soporte gancho



S - 700475-Cabideiro Alumínio (3x)  
Coat Rack / Perchero



T- 700419-Tapa furo (52x)  
cover / tapa



U - 700516-Sache cola 20g (1x)  
Glue / Goma



V- 700446-Porca cilíndrica (12x)  
Cylindrical Nut /  
Tuerca cilíndrica



W- 701145-Distanciador 25mm (8x)  
Distance 25mm /  
Distancia 25mm

01° PASSO Fixar os acessórios P nas peças 1,2 e 3.

01° STEP Attach accessories P to parts 1,2 and 3.

01° PASO Conecte los accesorios P a las partes 1,2 y 3.

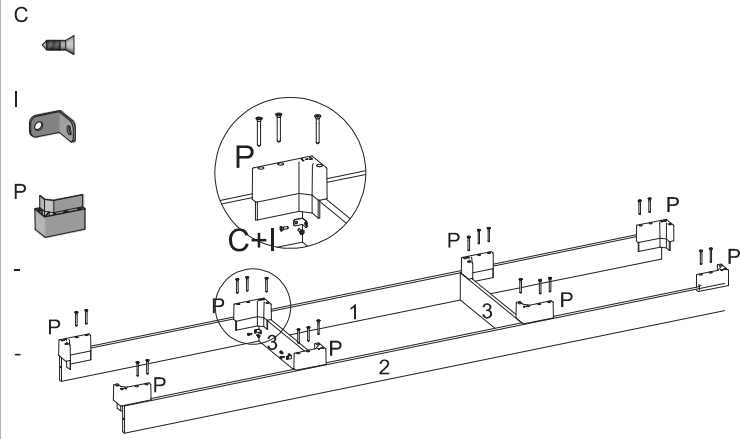

02° PASSO Fixar as peças 4,5 e 6 nas peças 1 e 2.

02° STEP Fix the pieces 4,5 and 6 on the pieces 1 and 2.

02° PASO Fija las piezas 4,5 y 6 en las piezas 1 y 2.

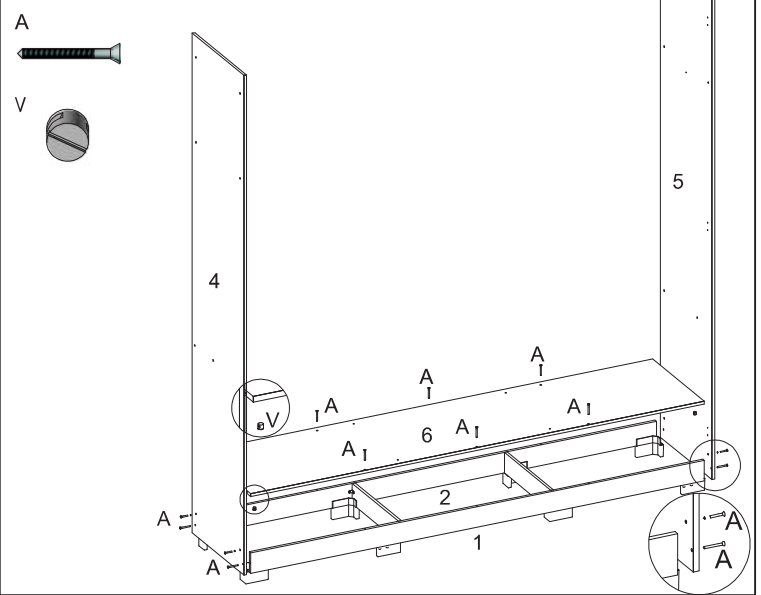

03° PASSO Fixar as peças 7 e 9 na peça 6, fixar as peças 8,10 e 11 nas peças 4,6,7 e 9.

03° STEP Fix parts 7 and 9 on part 6, fix parts 8,10 and 11 on parts 4,6,7 and 9.

03° PASO Arregle las partes 7 y 9 en la parte 6, arregle las partes 8,10 y 11 en las partes 4,6,7 y 9.

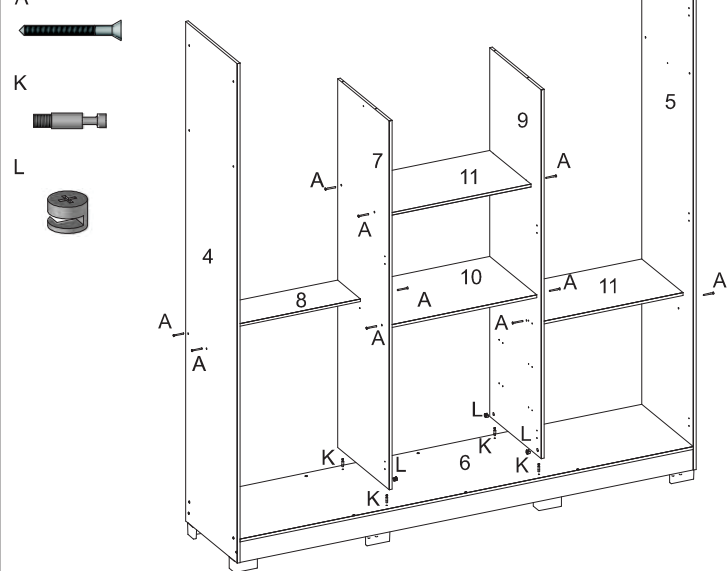

04° PASSO Fixar as peças 12 na peça 13, Fixar a peça 13 nas peças 4,5,7 e 9.

04° STEP Secure parts 12 to part 13, Secure part 13 to parts 4,5,7 and 9.

04° PASO Asegure las partes 12 a la parte 13, asegure la parte 13 a las partes 4,5,7 y 9.

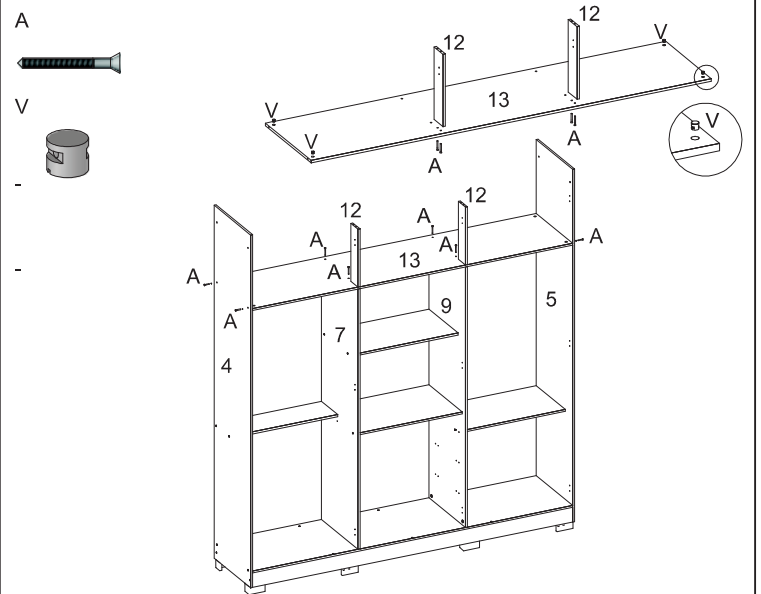

05° PASSO Fixar a peça 14 nas peças 4,5 e 12.

05° STEP Attach part 14 to parts 4,5 and 12.

05° PASO Adjunte la parte 14 a las partes 4,5 y 12.

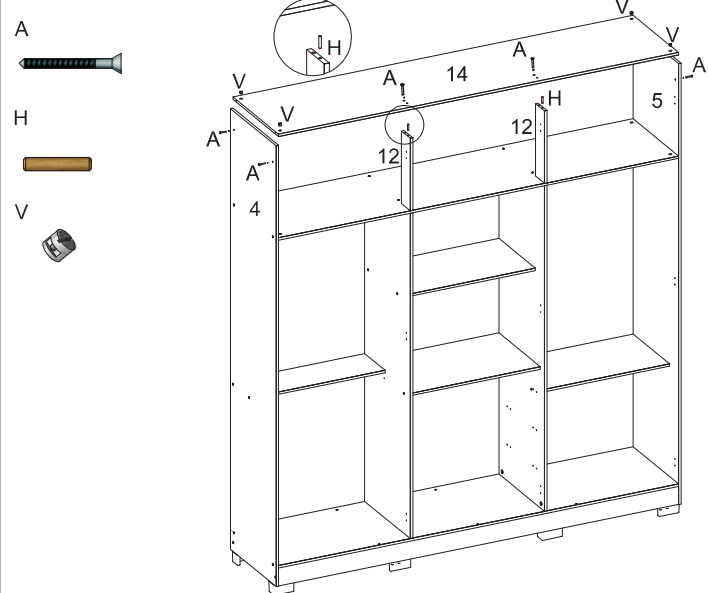

06° PASSO Fixar a peça 15 nas peças 4,5 e 15.

06° STEP Attach part 15 to parts 4,5 and 15.

06° PASO Adjunte la parte 15 a las partes 4,5 y 15.

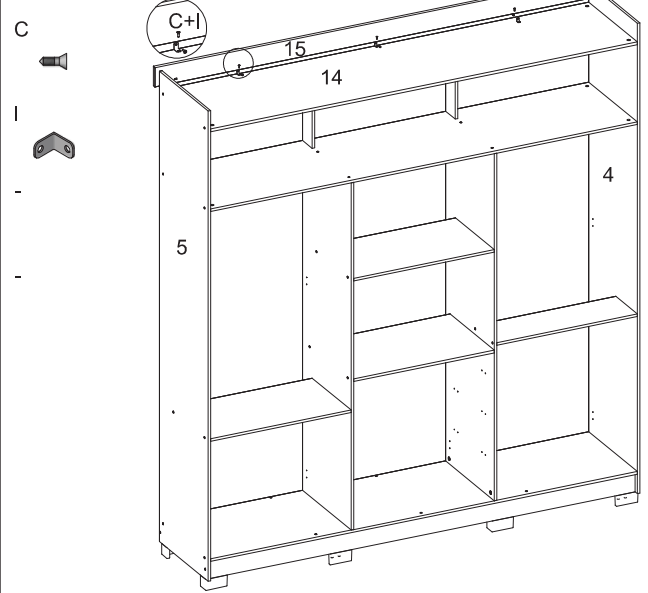

07° PASSO Fixar o acessório W nas peças 7 e 9, fixar o acessório R nas peças 4,5,7 e 9.

07° STEP Attach accessory W to parts 7 and 9, attach accessory R to parts 4,5,7 and 9.

07° PASO Conecte el accesorio W a las partes 7 y 9, conecte el accesorio R a las partes 4,5,7 y 9.

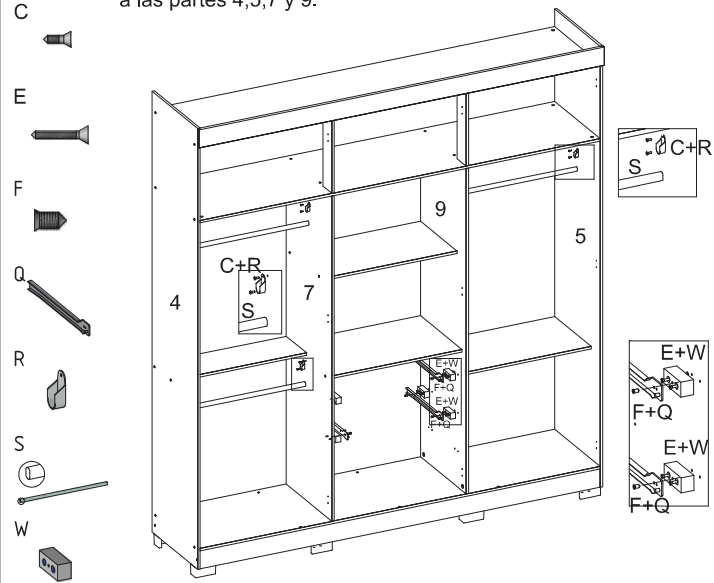

08° PASSO Fixar as peças 16 e 17 utilizando a ferragem J e M.

08° STEP Secure parts 16 and 17 using J and M hardware.

08° PASO Asegure las piezas 16 y 17 con hardware J y M.

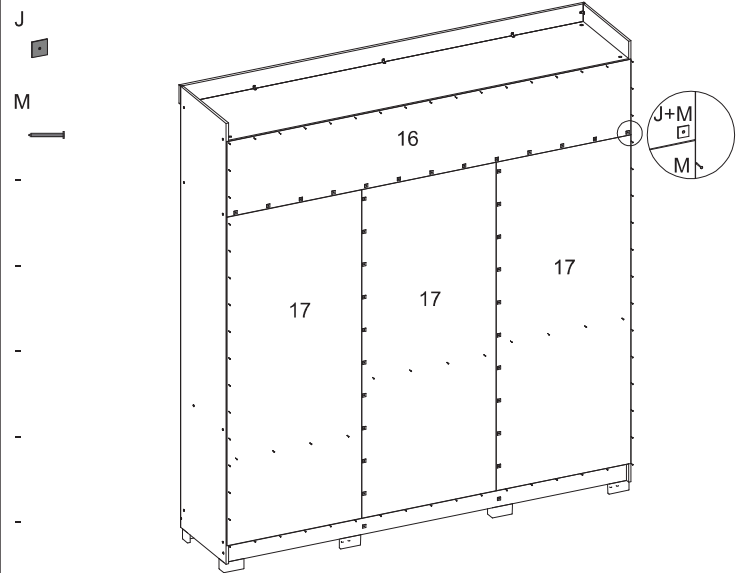

09° PASSO Fixar as peças 18 nas peças 4,5,7 e 9.

09° STEP Fix pieces 18 to pieces 4,5,7 and 9.

09° PASO Fijar las piezas 18 a las piezas 4,5,7 y 9.

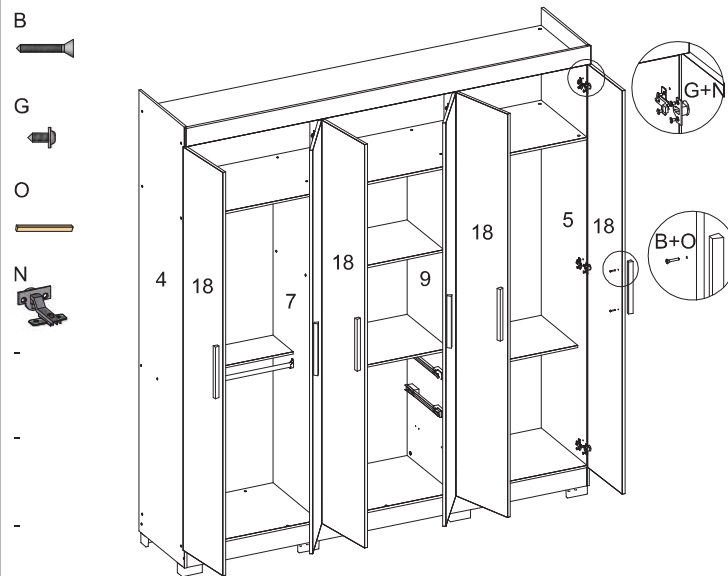

10° PASSO Fixar peças 20 nas peças 19 e 21. Fixar peça 22 nas peças 20 e 21.

10° STEP Fix part 20 to parts 19 and 21. Fix part 22 to parts 20 and 21.

10° PASO Fijar la pieza 20 en las piezas 19 y 21. Fijar la pieza 22 en las piezas 20 y 21.

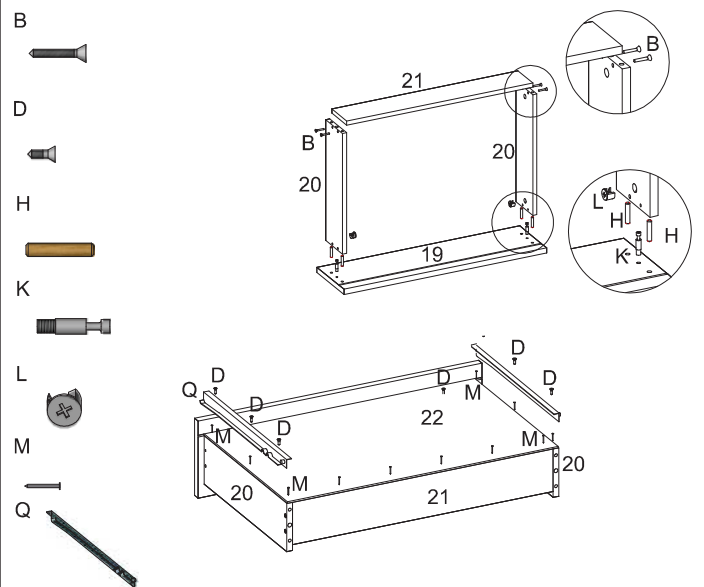

MONTAGEM PARA O PRODUTO QUE CONTEM ESPELHO  
ASSEMBLY FOR THE PRODUCT THAT CONTAINS MIRROR  
MONTAJE DEL PRODUCTO QUE CONTIENE ESPEJO

Atenção / Watch / Atención

Antes de colar o espelho. Favor, limpar a superfície da peça com um pano seco  
Before gluing the mirror. Please clean the surface of the piece with a dry cloth  
Antes de pegar el espejo Por favor, limpie la superficie de la pieza con un paño seco

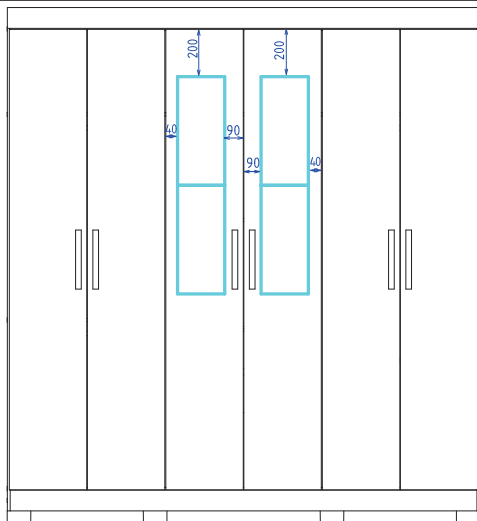

Aspecto final do produto

Final product aspect

Aspecto final del producto

